

### Features

- **Reliable foam proportioning system**
- **Suitable for multi hazard protection**
- **Easy to install**
- **Optional materials and fittings**
- **Wide range of available foam proportioners**

### Application

The bladder tank, together with ratio controllers, form a balanced pressure proportioning system used to mix water and firefighting foam together to generate an effective extinguishing medium.

The bladder tank technology is a reliable and precise mixing method that is widespread in the firefighting industry. This method allows to maintain the water/foam ratio stable by adjusting automatically to the variable flow rate and pressure conditions that may occur during the operation.

This feature makes bladdertanks particularly suitable to fit multiple hazard systems, sprinkler system and any other system operating under variable, non-predictable, flow or pressure conditions.

### Functional description

The bladder tank is a carbon steel pressure vessel (stainless steel construction optional) containing an elastomeric separation bladder between water and foam concentrate. The bladder permits water pressure to be transferred to the foam concentrate without these two fluids can mix together. A foam proportioner, as described in a separate data sheet, generates a water pressure drop where the water stream passes through. As foam concentrate pressure is higher than the water pressure inside the foam proportioner, the foam will be proportioned into the water stream at a pre-determined ratio.

### Construction features

- Vertical type on legs or horizontal type on saddles. Legs and saddles are provided with fixing holes
- Supplied with pre-piped/pre-trimmed or with separate ratio controllers
- Manufactured according to ASME Sec. VIII Div. I, EN13445 or ISPEL-VSR codes at Customer's choice
- Design pressure 175 psig (12.1 barg)
- 100% pressure tested according to the applied design code at a pressure of not less than 251 psig (17.3 barg)
- Shell and heads in ASTM A516 Gr. 70 or EN10028-3 P275NH/P355NH



- A106 Gr. B water and foam piping (stainless steel as an option)
- Machine welded circumferential and longitudinal seams for maximum quality and durability
- Welded lifting lugs for easy handling operations
- Earth lug
- Thermal relief valve provided on the water side
- Bladder in polyester reinforced hypalon-neoprene polymers, with an ASTM D-412 Tensile Strength of at least 6500 psi to ensure no ruptures under operation condition
- Bladder equipped with cast rubber caps to ensure water and foam tightness under constant pressurized condition
- Bladder tanks are oversized to permit concentrate thermal expansion (volume expansion allowance)
- Tank equipped with drain/fill/vent valves needed for full operation, made of corrosion resistant nickel covered brass

- Tank equipped with inside protection at any opening to ensure no damage to the bladder
- Internal PVC foam distribution pipe (one pipe for the vertical type, two orthogonal pipes for the horizontal type)
- Internal water distribution pipe to equalize the water pressure everywhere avoiding damage to the bladder and to drain the tank under any condition
- Nameplate in corrosion resistant material
- Nameplate holder to avoid undetected corrosion on the tank's shell behind the plate
- Analog level indicator instead of classic sight glasses to avoid foam soiling or foam leakage in case of ruptures
- External epoxy zinc rich primer/aliphatic polyurethane finish tested by FM for corrosive atmosphere

### Options

- Pre-piped version with optional foam proportioner
- Automatic water control valve
- Internal epoxy protective layer (recommended for salt-water applications) or external harsh-environment cycle
- Higher wall thickness for corrosion allowance
- Higher pressure ratings, seismic rating
- Ladders, work platforms, sunshade
- Water and foam piping in stainless steel AISI316 grade
- Full bladder tank stainless steel construction
- Manual or electrical filling pump
- Bladder tank and ratio controllers pre-assembled on skid or in container

### Standard material

Tank shell	ASTM A516 Gr. 70
	P275NH to EN10028-3
	P355NH to EN10028-3
Bladder	Polyester reinforced hypalon-neoprene polymers
Trim valves	Nickel coated brass
Thermal relief valve	Brass
Pressure gauges	Stainless steel
Level indicator	Stainless steel
Water and foam pipes	ASTM A106 Gr. B
Flanges	ASTM A105

### Standard design data

Design pressure	175 psig (12.1 barg)
Test pressure	≥ 251 psig (17.3 barg)
Design metal temperature(*)	-10 °C; +50°C
Capacity	See technical data
Empty weight	See technical data
Proportioning range	See proportioner data sheet

(\*) Temperature limitations normally come from foam concentrate and water

## Technical data

CAPACITY liters	Ød	A mm	B mm	C mm	ØD mm	T mm	ØF mm	WEIGHT (Kg) *
1000	2 ½"	2074	1485	765	1000	15	18	310
1500	2 ½"	2725	2140	765	1000	15	18	370
2000	2 ½"	2875	2290	835	1100	15	18	520
2500	3"	2967	2398	920	1200	15	25	800
3000	3"	3141	2544	995	1300	15	25	950
3500	3"	3197	2540	1065	1400	15	25	1080
4000	3"	3325	2654	1100	1450	15	25	1115
4500	3"	3352	2667	1135	1500	15	25	1260
5000	3"	3303	2591	1210	1600	15	25	1365
5500	3"	3553	2641	1210	1600	15	25	1445
6000	3"	3408	2642	1315	1750	15	25	1655
6500	3"	3457	2627	1350	1800	15	25	1715
7000	3"	2162	2278	1500	2000	20	25	2000
7500	3"	3312	2428	1500	2000	20	25	2075
8000	3"	3512	2628	1500	2000	20	25	2180
8500	3"	3662	2778	1500	2000	20	25	2255
9000	3"	3812	2958	1500	2000	20	25	2335
10000	3"	4162	3278	1500	2000	20	25	2520
11000	3"	4462	3578	1500	2000	20	25	2680
12000	3"	4812	3928	1500	2000	20	25	2860
13000	3"	5262	4378	1500	2000	20	25	3040
14000	3"	5612	4728	1500	2000	20	25	3220
15000	3"	5962	5078	1500	2000	20	25	3400

(\*) The table shows the approximate weight of the bladdertank without proportioner. The proportioner weight must be added to obtain the total weight (see the relevant data page). The weight shown refers to the ISPEL-VSR version, design pressure 175 psi (12,1 barg).

Ød ANSI 150# RF or DIN 150  
A105 or AISI316

Dimensions are in mm

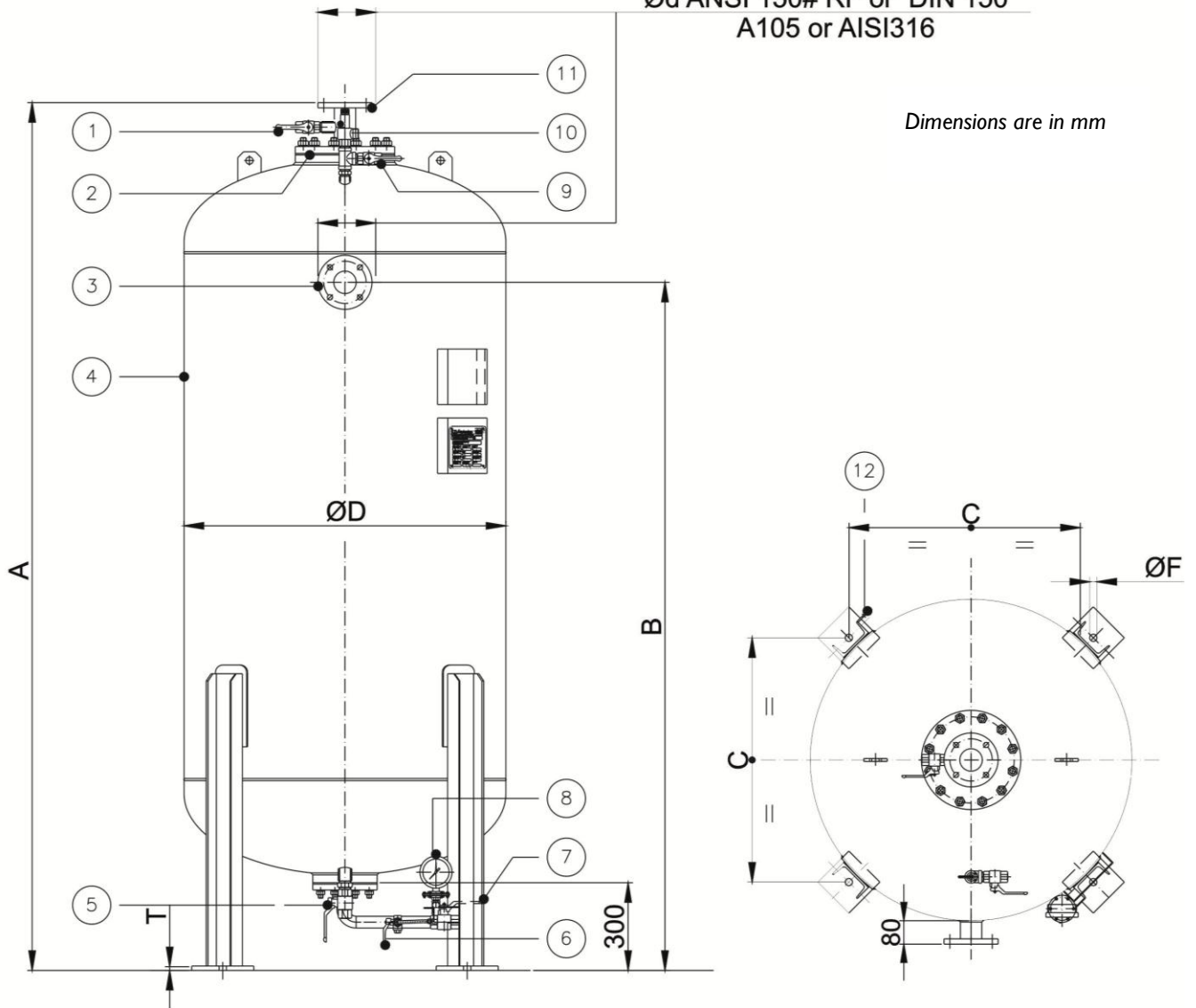

1. Foam Vent valve
2. Bladder
3. Water inlet flange
4. Tank
5. Water drain valve
6. Foam level indicator valve
7. Foam concentrate fill / drain valve
8. Foam level indicator
9. Water vent valve
10. Thermal relief valve
11. Foam outlet flange
12. Earth lug